

CLIENT:			
FRAME		KW	
VOLTS		RPM	

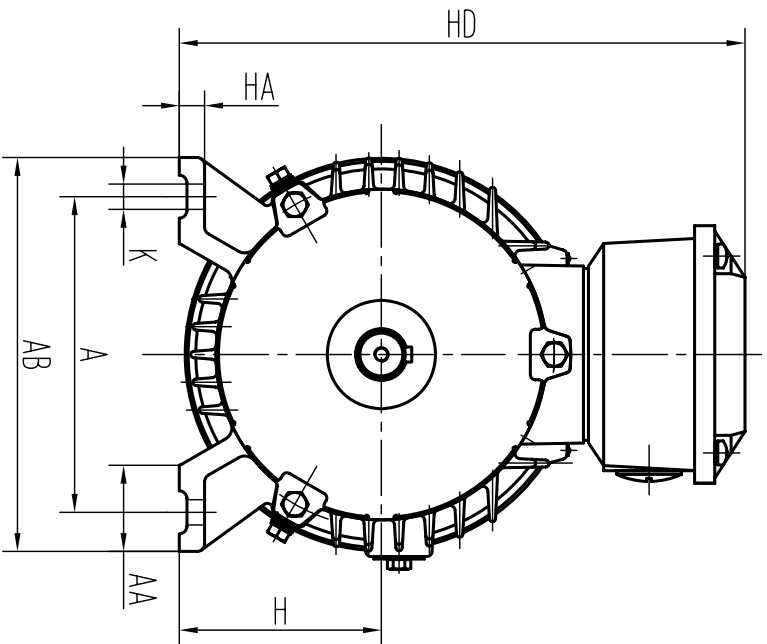
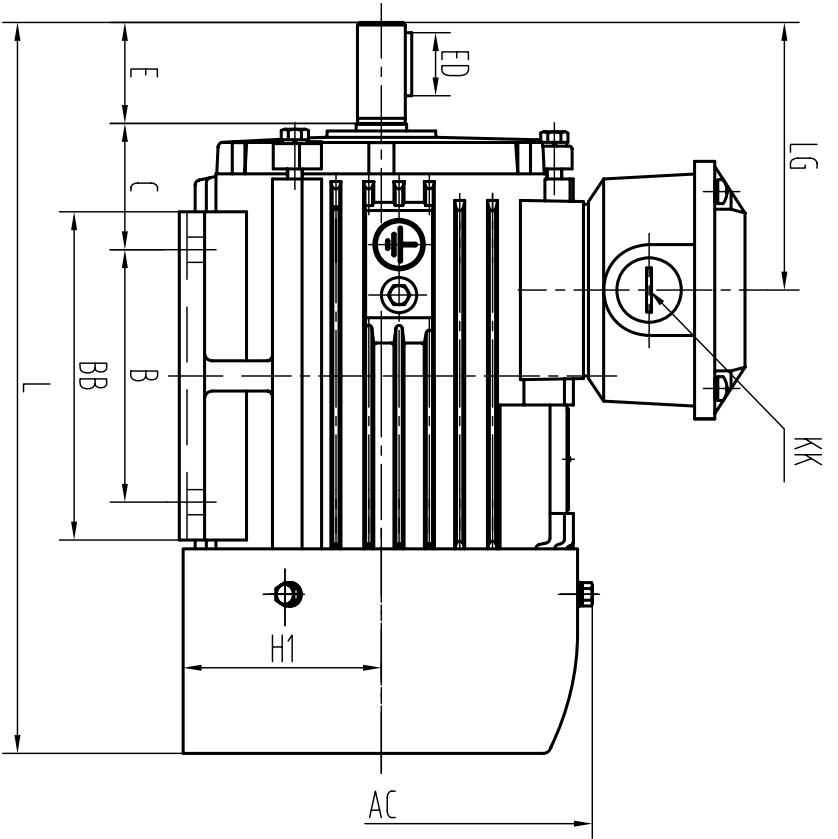
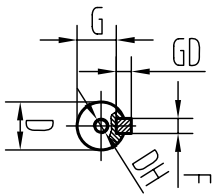

OUTLINE DIMENSIONS FOOT MOUNTED MOTORS

SHAFT EXT. DE ONLY

WEIGHT

125	A	34	AA	160	AB	175	AC	100	B	142	BB	50	C	80	H	78.5	H1	10	HA	230	HD	10	K	M25X1.5	KK	305	L	112	LG	ø19	D	M6X16	DH	40	E	25	ED	6	F	15.5	G	6	GD
-----	---	----	----	-----	----	-----	----	-----	---	-----	----	----	---	----	---	------	----	----	----	-----	----	----	---	---------	----	-----	---	-----	----	-----	---	-------	----	----	---	----	----	---	---	------	---	---	----

CUSTOMER APPROVAL

SIGNATURE

DATE

21-80 2-8P (B3)
DIMENSION OUTLINE

DATE	2011.5.8	CHK
DRAWN	Mao	APPD
ISSUE A DATE		CERTIFIED BY
ISSUE B DATE		CERTIFIED BY
ISSUE C DATE		CERTIFIED BY
ISSUE D DATE		CERTIFIED BY